



7.62 X 39 mm

BALL FMJ M67 - 8,0 g (124 gr)

7.62 x 39 mm FMJ

The cartridge consists of case, primer, gunpowder and bullet. It is applicable in extreme polar or desert conditions, contributing to the versatility of its use.

7.62 x 39 mm - FMJ bullet

The FMJ (Full Metal Jacket) bullet weighs 8.0 g (124 gr) and features a lead core made from a PbSb (lead-antimony) alloy for improved hardness and penetration. The jacket is made of CuZn10, ensuring durability and consistent ballistic performance.

7.62 x 39 mm - case

The caliber 7.62 x 39 mm CuZn30 case is intended for inserting the powder charge, primer and bullet.

SPECIFICATIONS

Technical Specification

CARTRIDGE

Caliber	7.62 x 39 mm, M67
Weight	max 17.50 g
Length	max 55.80 mm

BULLET GRAIN

Type	FMJ, Ball
Weight	8.0 g \pm 0.1 g (124 grain)
Length	max 23.90 mm
Material	Jacket - CuZn10; Core - Lead
Extraction	\geq 156 N

CASE

Length	max 38.7 mm
Material	CuZn30

PRIMER

Type	Boxer, non-corrosive, non-toxic
Propellant	Smokeless Powder (Double Base)
Waterproof	Sealant applied

The 7.62x39mm, M67, Ball, ammunition producing in Mark1 Ammo is in compliance with VTI requirements as well as the requirements of MIL-C-50701A. The ammunition can be fired from AK-47, LEAD STAR ARMS GRUNT 7.62X39 AR-15, Zastava ZPAPM70.

ELECTRONIC PRESSURE AND VELOCITY (KIAG 6215)			
Ammunition Temperature	+21°C ± 2°C	+52°C & -54°C	
Velocity (at 24 m, m/s)	V = 710 ± 8 m/s	No requirement	
Standard Deviation	≤ 9.7 m/s	No requirement	
Max Corrected Mean Case Mouth Pressure, MPa	XCP ≤ 310 Mpa	XCP ≤ 330 Mpa	
Min Corrected Mean Port Pressure, MPa	No requirement	No requirement	
Action Time (ms)	Max individual ≤ 4 ms	No requirement	
Muzzle Energy (at 0 m, J)	≤ 1600 J	No requirement	
Precision (at 300 m)	Mr ≤ 150 mm		
Precision (at 183 m)	Mr ≤ 127 mm		
Precision (at 50 m)	Mr ≤ 30 mm		
Function and Casualty	Permissible percentage of defects was not exceeded		
Primer sensitivity critical high method (run down)	Test ball 111.7 ± 0.57 g	H +5 SD ≤ 500	H - 2 SD ≤ 75
Waterproof test	No more than 15% of the tested rounds have leaks		

Compatibility with: VTI (Voeno tehnicki institut), MIL-C-52701A.

PACKING	
Micro	20 rounds fiberboard box
Macro	540 rounds, ADR 1.4 S, UN0012 certified fiberboard case
Weight (540 rounds)	Net: 9.32 kg (±0.04 kg)
	Gross: 9.88 kg (±0.04 kg)
	NEQ: 0.92 kg
Hazard class	1.4 S
UN Classification	CARTRIDGES, SMALL ARMS

Packaging options are available based on the buyer's request. Cartridges can be supplied in standard outer cartons or, for an additional cost, in metal M2A1 boxes. All shipments are palletized, with boxes and pallets marked according to the customer's specifications.

V = Corrected mean velocity
XCP = Corrected mean chamber pressure

Test Equipment

The equipment that is used for testing the ballistic characteristics of the ammunition is from Prototypa and is as follows:

- Universal Ballistic Breech (Receiver) UZ-2002
- Support reducing inserter UZ-2002
- Exchangeable parts sets for cal. 7,62x39 and 7,62x51 -for action time measuring:
 - Breech block head insulated marked 2 INM
 - Firing pin insulated marked 2 INA
 - Extractor marked 2
 - Firing pin spring
 - Extractor spring
 - Extractor cap - Rivet 3x8
 - Firing pin end
- Pressure Test Barrel cal. 7,62x39 for Receiver M2; Length = 600 mm, KISTLER 6215 pressure vent position M1=25 mm
- Pressure Test Barrel cal. 7,62x39 for Receiver M2; Length = 520 mm, KISTLER 6215 pressure vent position M1-41.43 mm
- Velocity/Accuracy Test Barrel cal. 7,62x39 for Receiver M2; Length = 520 mm
- Velocity/Accuracy Test Barrel cal. 7,62x39 for Receiver M2; Length = 600 mm
- Velocity/Accuracy Test Barrel cal. 7,62x39 for Receiver M2; Length = 650 mm
- VPS-Simple one purpose drilling jig for cal. 7.62x39 mm
- Head space gauge GO and NOGO cal. 7,62x39 mm.
- SAU-4QU Signal acquisition unit
 - 4 charge inputs for transducers/voltage inputs (programmable)
- Quartz High pressure Sensor KISTLER 6215A1
- LS06 Intelligent Light gates
 - Diode system, Base 1 m, software BMS - English
- BP-1 Bullet pull tester.
- Range of calibers from 4,5 to 12 mm
- Maximum load 2500 N

The equipment is controlled, maintain, and calibrated according to the specifications. We are always aiming for improving the testing facility with latest in line equipment's and assuring that the possibility of mistake is reduced to the minimum.

Outsourcing Components

Mark1 Ammo has its own top-to-bottom manufacturing of a finished Product, an output of In-house made Machines, and produces 100% In-house Materials, Components and Tooling). Mark1 Ammo 7.62 x 39 mm components (bullet, case, primer) are perfectly compact, customizable and available for individual purchase.

PRIMER
No mercury
CuZn30

 <small>Case Length: max 38.70 mm</small>
CASE 7.62 x 39 mm
Unprimed
CuZn30

 <small>Grain Bullet Length: max 23.90 mm</small>
M67 FMJ BALL
8 g 124 grain
CuZn10 Lead Core

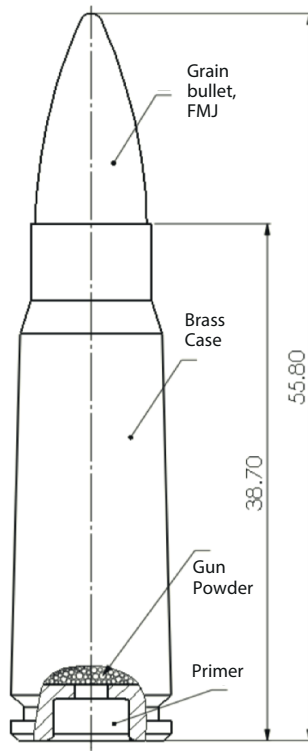

Image: Components Layout (7.62 x 39 mm)
Part number: 7621039